

City of Tipton, Iowa

Meeting: Tipton City Council Meeting
Place: Tipton Fire Station, 301 Lynn Street, Tipton, Iowa 52772
Date/Time: Monday, January 31, 2022, 5:30 p.m.
Web Page: www.tiptoniowa.org
Posted: Friday, January 28, 2022 (Front door of City Hall & City Website)

Go to Meeting link:

Please join my meeting from your computer, tablet or smartphone.

<https://global.gotomeeting.com/join/579615189>

You can also dial in using your phone.

United States (Toll Free): [1 866 899 4679](tel:18668994679)

United States: [+1 \(571\) 317-3116](tel:+15713173116)

Access Code: 579-615-189

Mayor: Bryan Carney

Council at Large:	Abby Cummins-VanScoy	Council At Large:	Jason Paustian
Council Ward #1	Ron Hembry	Council Ward #2	Mike Helm
Council Ward #3	Tim McNeill	City Attorney:	Lynch Dallas, P.C.
City Manager:	Brian Wagner	Gas Utilities Supt:	Adam Fitch
Finance Director:	Melissa Armstrong	Electric Utilities Supt:	Floyd Taber
City Clerk:	Amy Lenz	Water & Sewer Supt:	Brian Brennan
Dir. Of Public Works:	Steve Nash	Ambulance Svc Dir:	Brad Ratliff
Police Chief:	Lisa DuFour	Economic Dev. Dir.	Linda Beck
Park & Recreation:	Adam Spangler	Library Director:	Denise Smith

Call to Order

A. Roll Call

B. Pledge of Allegiance

C. Agenda Additions/Agenda Approval

D. Communications

E. City Business

1. Discussion and possible action concerning the purchase of dehumidifiers for the JKFAC
2. Discussion and possible action concerning the purchase of pumps for the JKFAC
3. Discussion and possible action concerning the proposed appraisal review for Homerding parcel
4. Closed Session. Closed session pursuant to Iowa Code Chapter 21.5(1)(c) to discuss strategy with counsel in matters that are presently in litigation or where litigation is imminent where its disclosure would be likely to prejudice or disadvantage the position of the governmental body in that litigation.
5. Discussion and possible action authorizing course of action resulting from the previous closed session.

F. Adjournment

Pursuant to §21.4(2) of the Code of Iowa, the City has the right to amend this agenda up until 24 hours before the posted meeting time. If anyone with a disability would like to attend the meeting, please call City Hall at 886-6187 to arrange for accommodations/transportation.

AGENDA ITEM #

**AGENDA INFORMATION
TIPTON CITY COUNCIL COMMUNICATION**

DATE:	January 31, 2022
AGENDA ITEM:	Dehumidifiers at James Kennedy Aquatic Center
ACTION:	Motion

SYNOPSIS:

At the last council meeting we discussed the need of dehumidifiers within the indoor pool at the James Kennedy Aquatic Center until all repairs are finished. After looking into multiple places to purchase dehumidifiers we went through USA BlueBook out of Illinois. Instead of renting dehumidifiers this way we will own two of them and can be used at the aquatic center or at the water plant.

Cost to purchase was \$6,723.63

I will be in attendance for the meeting if you have any further questions.

BUDGET ITEM: No

RESPONSIBLE DEPARTMENT: Aquatic Center

MAYOR/COUNCIL ACTION: Motion

ATTACHMENTS: USA BlueBook, AMG & Sylvane

PREPARED BY: Adam Spangler

DATE PREPARED: 1/28/22

QUOTATION
 HDSFM
 D/B/A USABBLUEBOOK
 PO Box 9004
 Gurnee, IL 60031-9004
 Toll free: 1-800-548-1234
 Fax: (847) 689-3030

NO. 498735
 Page 1
 01/26/22

Ship-to: 1
 TIPTON CITY OF

 700 PARK RD
 TIPTON, IA 52772
 USA

Bill-to: 67708
 TIPTON CITY OF

 407 LYNN ST
 TIPTON IA 52772
 USA

REFERENCE #	EXPIRES	SLSP	TERMS	WH	FREIGHT	SHIP VIA
1.26.22	02/25/22	CMC	NET 30	01	FXD/PPD	ESTES

QUOTED BY: CMC | QUOTED TO: ADAM SPANGLER

ITEM	DESCRIPTION	QUANTITY	UM	PRICE	UM	EXTENSION
330149	Quest Hi-E Dry 195 Dehumidifier	2	EA	3285.00	EA	6570.00
	IN STOCK AT TIME OF QUOTE					
	PLEASE PROVIDE DAYS AND HOURS FOR DELIVERY					

Any quoted item(s) without a 5 digit stock # is not normally stocked by USABBlueBook and is not normally returnable for credit UNLESS it is determined to be defective and covered under the vendor's warranty. With this in mind, please carefully review this quote BEFORE ordering to be certain it is appropriate for your application. This quote and all sales by HD Supply Facilities Maintenance, Ltd. d/b/aUSABBlueBook shall be governed exclusively by the Terms of Sale available at hdsupplysolutions.com/terms.

Please note that your order may be subject to applicable taxes based on current rates at the time your order is completed.

CONTINUED

QUOTATION
 HDSFM
 D/B/A USABLUEBOOK
 PO Box 9004
 Gurnee, IL 60031-9004
 Toll free: 1-800-548-1234
 Fax: (847) 689-3030

NO. 498735
 Page 2
 01/26/22

Ship-to: 1
 TIPTON CITY OF

 700 PARK RD
 TIPTON, IA 52772
 USA

Bill-to: 67708
 TIPTON CITY OF

 407 LYNN ST
 TIPTON IA 52772
 USA

REFERENCE #	EXPIRES	SLSP	TERMS	WH	FREIGHT	SHIP VIA
1.26.22	02/25/22	CMC	NET 30	01	FXD/PPD	ESTES

QUOTED BY: CMC | QUOTED TO: ADAM SPANGLER

ITEM	DESCRIPTION	QUANTITY	UM	PRICE	UM	EXTENSION
------	-------------	----------	----	-------	----	-----------

TO ORDER --
 For your convenience, you may simply sign below and return via fax to 847-689-3030. We will process your order promptly and fax a confirmation so you know we have it. If you prefer to call your order in or have additional questions or concerns, you may contact our Customer Service Department @ 800-548-1234. Please note any changes to the quantities or shipping address. Thanks for choosing USABlueBook.

 Authorization Signature

 PO Number (if required)

MERCHANDISE	MISC	TAX	FREIGHT	TOTAL
6570.00	.00	.00	153.63	6723.63

USE THIS QUOTE # ON PO's!

AGENDA ITEM #

**AGENDA INFORMATION
TIPTON CITY COUNCIL COMMUNICATION**

DATE:	January 31, 2022
AGENDA ITEM:	Geothermal pumps at James Kennedy Aquatic Center
ACTION:	Motion

SYNOPSIS:

We are in need of replacing two geothermal pumps in the west mechanical room. Quote attached is from Kraus. Both pumps are the original pumps since we have been open since 2005. One pump is unrepairable and the other starting really acting up about a month ago. We had them look it over and that one is about the same as the first. That is why they suggest replace both of them at the same time. These pumps are two of the four pumps that help run the entire system for the indoor pool area and the west side of the building as well.

Cost to replace is \$12,250.43

I will be in attendance for the meeting if you have any further questions.

BUDGET ITEM: No

RESPONSIBLE DEPARTMENT: Aquatic Center

MAYOR/COUNCIL ACTION: Motion

ATTACHMENTS: Kraus

PREPARED BY: Adam Spangler

DATE PREPARED: 1/28/22

JOB: Aquatic Center Series 80 Replacement

REPRESENTATIVE: SANDBERG CO.

UNIT TAG:
ENGINEER:
CONTRACTOR:

ORDER NO.
SUBMITTED BY:
APPROVED BY:

DATE: 1/24/2022
DATE:
DATE:



Series e-80 2x2x7B Close Coupled In-Line Centrifugal Pump

DESCRIPTION:

The Series e-80 is a highly efficient, heavy duty, close coupled pump designed for horizontal or vertical in-line mounting. The e-80 is available in stainless steel fitted construction, with flows up to 2500 GPM, heads to 380 feet.

SPECIFICATIONS

FLOW _____	HEAD _____
HP 7.5	RPM 3600
VOLTS _____	230/460
CYCLE 60	INPUT PHASE 3
ENCLOSURE _____	ODP Nema Premium Efficient
APPROX. WEIGHT _____	270
SPECIALS _____	

MATERIALS OF CONSTRUCTION

Stainless Steel Fitted

MAXIMUM WORKING PRESSURE

- 175 psi (12 bar) with 125# ANSI flange drilling
- 250 psi (17 bar) with 250# ANSI flange drilling (requires e-80-S)
- 300 psi (21 bar) W.P. with 250# ANSI flange drilling (Requires -S and EPR-Silicon Carbide-Silicon Carbide Seal)

MOUNTING

- In-Line Piping
- Flange Supports

PARALLEL SENSORLESS CONTROLLER

- Pump Mounted
- Wall Mounted
- _____ Pumps in Parallel

PUMP VARIABLE SPEED CONTROL

- Integrated Technologic® Sensorless Control (ITSC)
- Integrated Technologic® (IT)
 - External input by others
 - Pressure Sensor(s)
 - Differential Pressure Sensor(s)
 - Flow Sensor(s)
- By Others

TYPE OF SEAL

- F Standard Seal w/ Flush Line (Buna-Carbon/Ceramic)
 - 20° to 225°F (-29° to 107°C)
 - Max working pressure 175 psi (12 bar)
- S Stuffing Box construction w/ Flushed Mechanical Single Seal (EPR-Tungsten Carbide/Carbon)
 - 20° to 225°F (-29° to 107°C)
 - Max working pressure 175 psi (12 bar)
- PF Stuffing Box Construction w/ Flushed Packing (Graphite Impregnated PTFE)
 - 20° to 300°F (-29° to 149°C)
 - Max working press. 175 psi (12 bar) or 300 psi (21 bar)

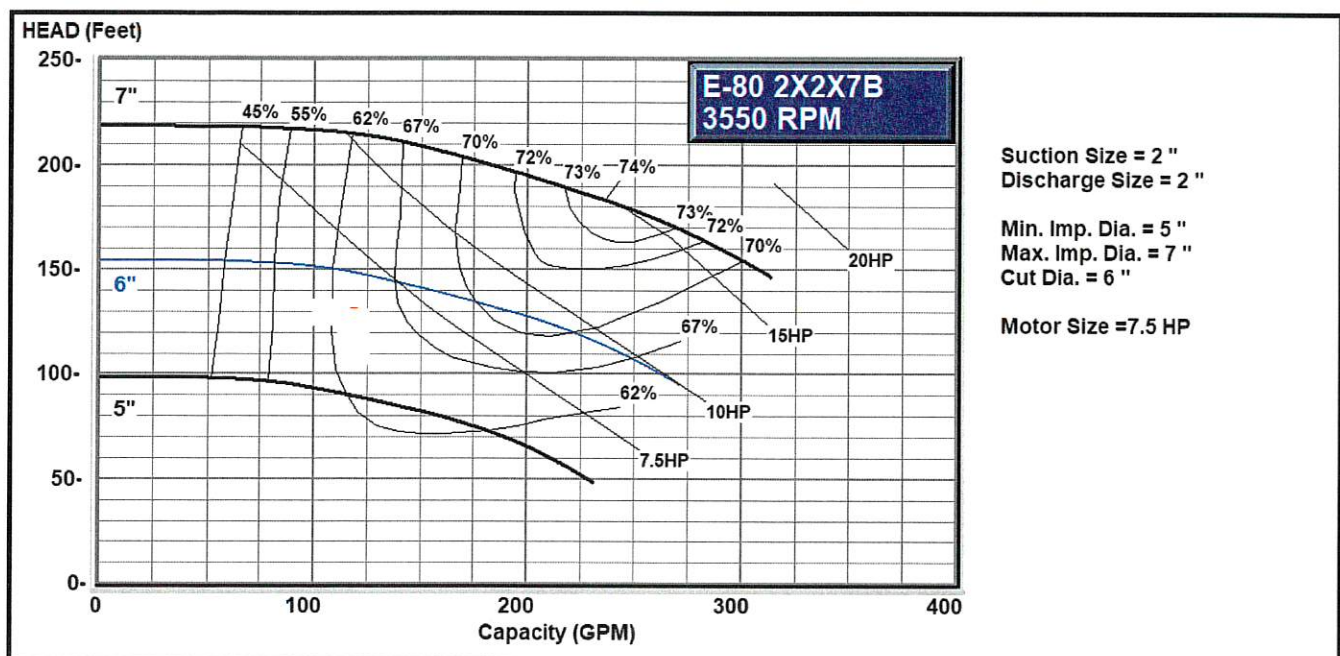

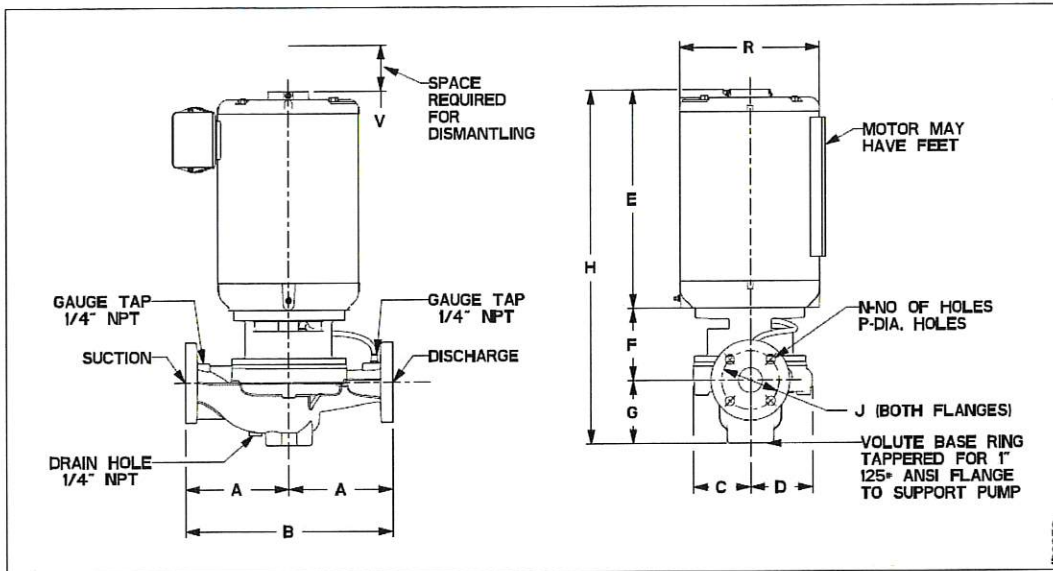

In-Line Piping

MOTOR FRAME	DIMENSIONS - Inches (mm)								STANDARD SEAL						R	S (Max)*	V (min)	Suct/Disch Gauge Taps (NPT)	Drain Tap (NPT)
	A	B	C	D	E (max)	F	G	H (max)	125# ANSI			250# ANSI							
	J	N	P	J	N	P													
143JM	8.50 (216)	17.00 (432)	4.65 (118)	5.12 (130)	11.63 (295)	4.63 (117)	5.13 (130)	21.38 (543)	4.75 (121)	4	0.75 (19)	5.00 (127)	8	0.75 (19)	9.75 (248)	1.50 (38)	4.00 (102)	0.25	0.25
145JM	8.50 (216)	17.00 (432)	4.65 (118)	5.12 (130)	12.63 (321)	4.63 (117)	5.13 (130)	22.38 (568)	4.75 (121)	4	0.75 (19)	5.00 (127)	8	0.75 (19)	9.75 (248)	1.50 (38)	4.00 (102)	0.25	0.25
182JM	8.50 (216)	17.00 (432)	4.65 (118)	5.12 (130)	15.31 (389)	4.63 (117)	5.13 (130)	25.06 (637)	4.75 (121)	4	0.75 (19)	5.00 (127)	8	0.75 (19)	11.75 (298)	1.00 (25)	4.00 (102)	0.25	0.25
➔ 184JM	8.50 (216)	17.00 (432)	4.65 (118)	5.12 (130)	15.31 (389)	4.63 (117)	5.13 (130)	25.06 (637)	4.75 (121)	4	0.75 (19)	5.00 (127)	8	0.75 (19)	11.75 (298)	1.00 (25)	4.00 (102)	0.25	0.25
213JM	8.50 (216)	17.00 (432)	4.65 (118)	5.12 (130)	19.25 (489)	4.63 (117)	5.13 (130)	29.00 (737)	4.75 (121)	4	0.75 (19)	5.00 (127)	8	0.75 (19)	14.00 (356)	0.00	4.00 (102)	0.25	0.25
215JM	8.50 (216)	17.00 (432)	4.65 (118)	5.12 (130)	19.25 (489)	4.63 (117)	5.13 (130)	29.00 (737)	4.75 (121)	4	0.75 (19)	5.00 (127)	8	0.75 (19)	14.00 (356)	0.00	4.00 (102)	0.25	0.25
254JM	8.50 (216)	17.00 (432)	4.65 (118)	5.12 (130)	24.13 (613)	5.63 (143)	5.13 (130)	34.88 (886)	4.75 (121)	4	0.75 (19)	5.00 (127)	8	0.75 (19)	17.00 (432)	0.00	4.00 (102)	0.25	0.25

Dimensions are subject to change. Not to be used for construction purposes unless certified.

NOTE: For Single phase Motors add 1" to dimensions E & H.

*Dimensions are for ODP Motors. For TEFC add S dimension to dimensions E & H.



Xylem Inc.
 8200 N. Austin Avenue, Morton Grove, IL 60053
 Phone: (847)966-3700 Fax: (847)965-8379
 www.xylem.com/bellgossett
 Bell & Gossett is a trademark of Xylem Inc. or one of its subsidiaries.
 ESP-REP v2021.05 © 2020 Xylem Inc.

Review Appraisal Proposal

January 25, 2022

Mr. Jay Pudenz, Team Leader
Consultant for the City of Tipton
McClure Engineering
1360 NW 121st Street
Clive, Iowa 50325

Re: Tipton Matthews Airport Project
Proposed Appraisal Review Services
Cedar County, Iowa

Parcel/Owner	Proposed Fee
Homerding-Update	\$1,400.00 per appraisal reviewed

Thank You,

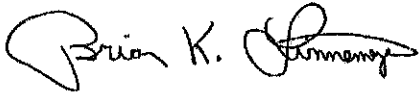

Brian K. Linnemeyer
State of Iowa Certified General Appraiser-#CG01153